

Buanson Tiex Phon

Benefits of fertilizer

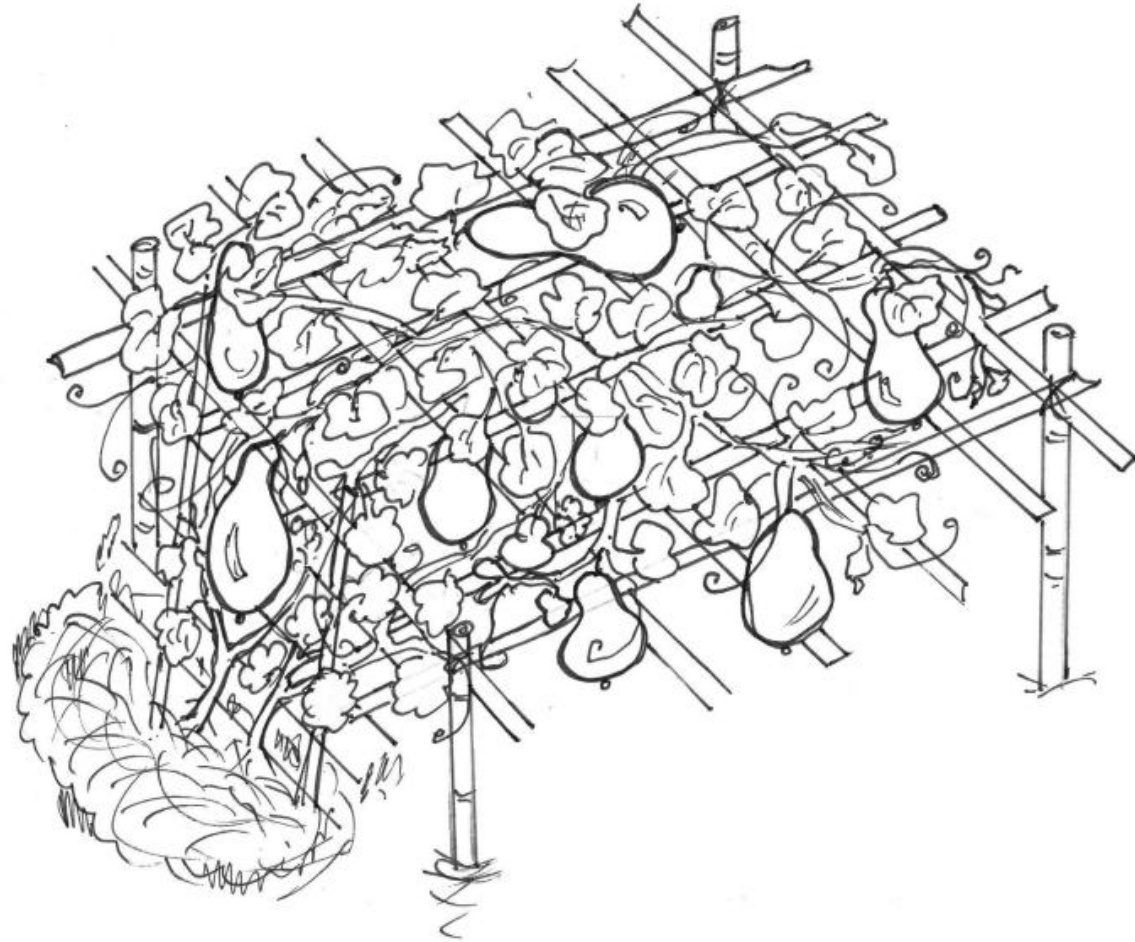

Wa, Parauk

Buanson Tiex Phon

Benefits of fertilizer

Cao Tiiem Lih : Ying Miaw

Cao Pawd Riieng : Khu "Cang", Ying Miaw

Lox Lai Shiao : Lai Vax

Teei Khaing : Lai Been Lachit

Cao Toe lih : Sai Rong Khun

Bawg Plih Lih : Bawg (1)

Khix Num : 9 / 2021

Author : Ying Myaw

Illustrator : Khoo "Cang", Ying Myaw

Original Language : Lacid

Translated Language : Wa

Translator : Sai Rong Khun

Edition : First Print

Date : Sep / 2021

Wa, Parauk
Myanmar

Copyright © 2021, Literature Department Of WBC, SIL

For permission to reuse, contact the copyright holder.

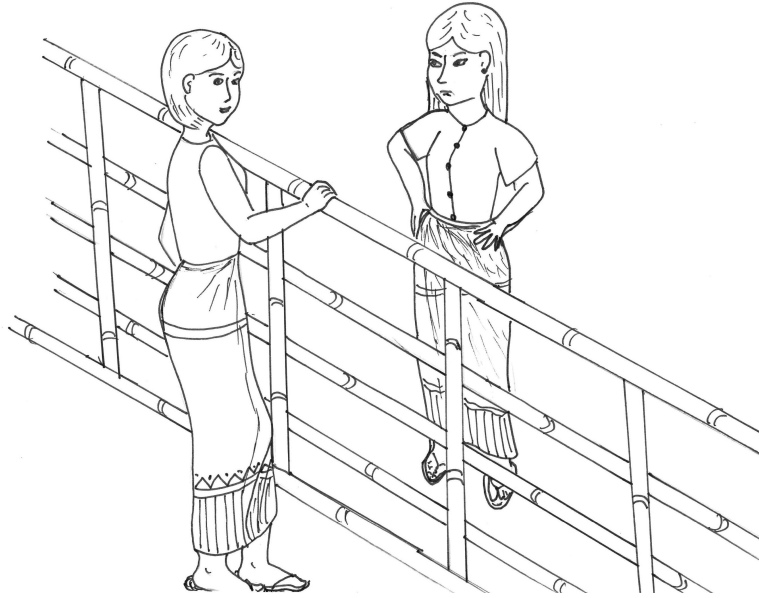

Didix koe pui pa mhawm rhawm pa kaux Yex Yung mai pui pa ang mhawm rhawm pa kaux Am Pao, kiex mawh paox plawg tau heue.

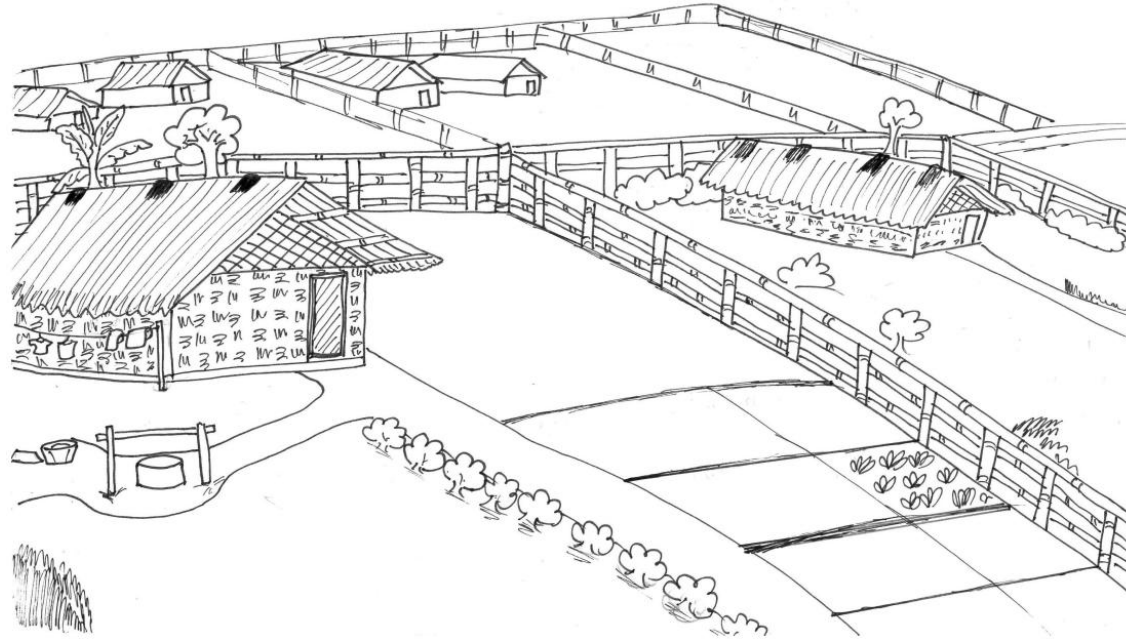

Yex Yung yuh krax singax sivie siveng mai nawh sum ti
ih taux lhax dee tan heue.



Mawh kheu Am Pao ang mhawm rhawm, nawh tom tik
briem daux quang sipeem nyiex Yex Yung heue.



Yex Yung pa mhawm rhawm an, nawh tom khrawm ka
briem pa tik Am Pao ankix mai gleeing ka ngu heue.



Yam bleeh bawg yam sau simie, Yex Yung tom teei
simie singiien nawh tom sum dee gleeing nawh briem heue.

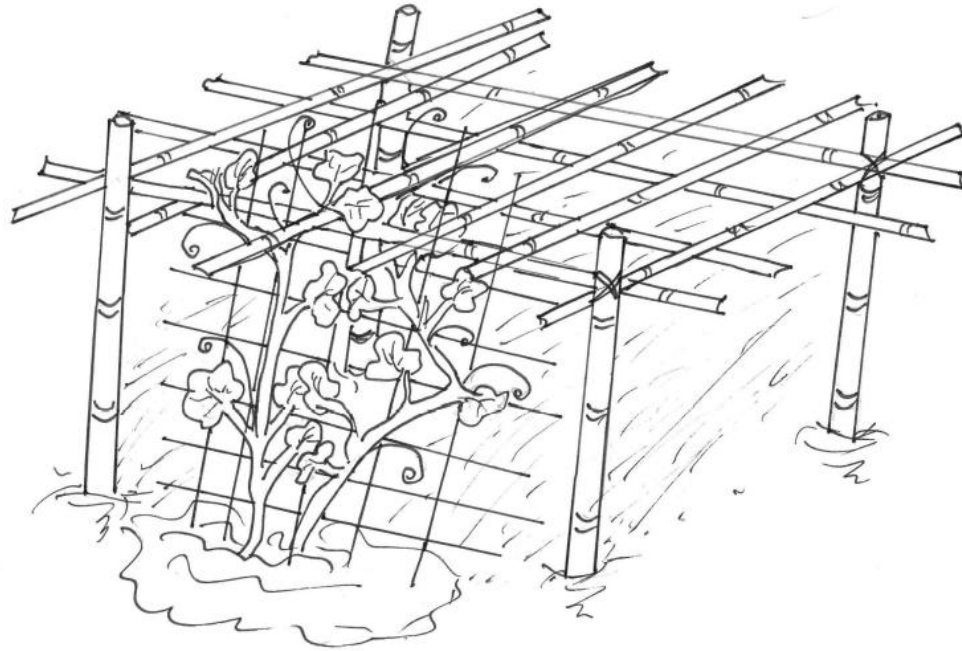

Khaix kuah singiien an Yex Yung tom teei ox mai yuh
grah singiien, singiien an kawx jied mhawm heue.

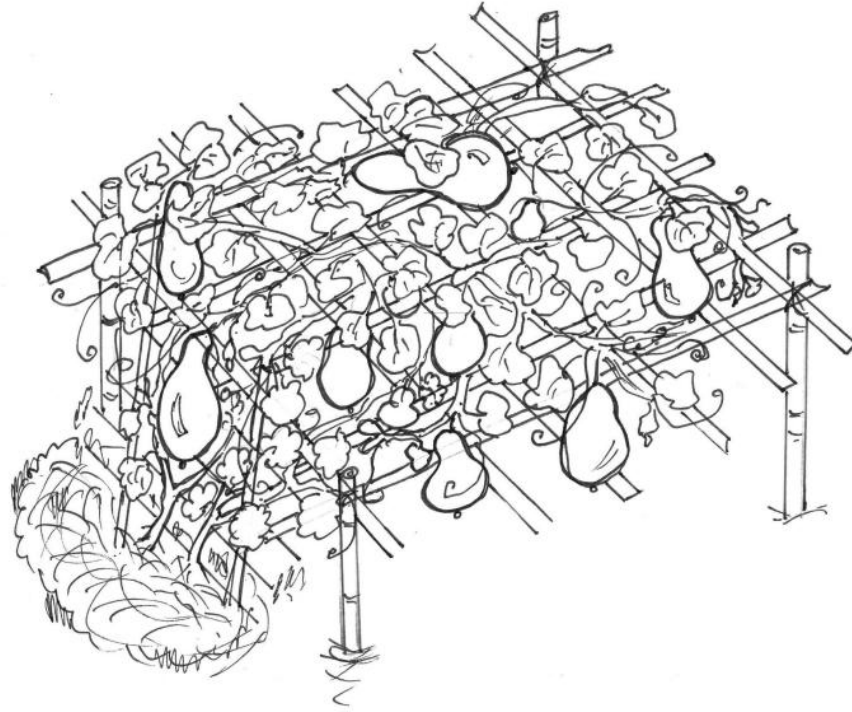

Tix ngaix hoek tix ngaix, singiien an jied plix plix tom
nie heue.



Yex Yung pieh plix singiien an mai nawh rhoi ti tawx
paox plawg paox nyawm tix ih heue.



Nawh tom ah nin ka Am Pao "Kheu khrawm aux ti
gleeing briem pa tik maix, plix singiien tom plix plix yuh nin,
ting buanson awx" mai tawx plix singiien ka nawh heue.



Am Pao nawh tom kaig tua kheu grawng pa yuh nawh ka ceu pa ang mhawm heue. Am Pao tom ah "Paox grawm eue, aux kawx sang yuh ti mawh pui pa mhawm rhawm awm maix" ka Yex Yung heue.

